

Bronze Ball Valves

Two-Piece Body • Standard Port • Blowout-Proof Stem • TFE Seats

400 PSI/28 Bar Non-Shock Cold Working Pressure

NSF/ANSI 61-8 • IAPMO LISTED

MATERIAL LIST

PART	SPECIFICATION
1 Body	Forged Brass Cu > 57%
2 End Cap	Forged Brass Cu > 57%
3 Ball Seat	PTFE
4 Ball	Brass, Chrome Plated
5 Stem	Forged Brass
6 O-Ring	FKM Fluorocarbon
7 Stem Packing	PTFE
8 Packing Nut	Machined Brass
9 Lever Handle	Steel, Plated
10 Lock Washer	Stainless Steel
11 Stem Nut	Stainless Steel



T-580-A
Threaded



S-580-A
Solder

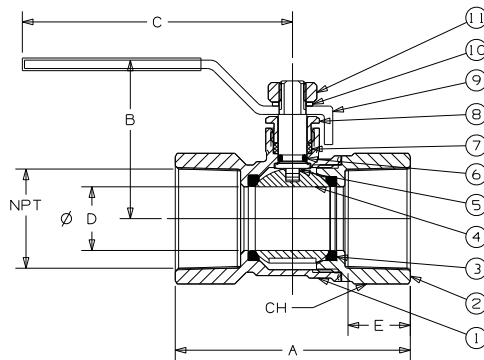

T-580-A
NPT x NPT

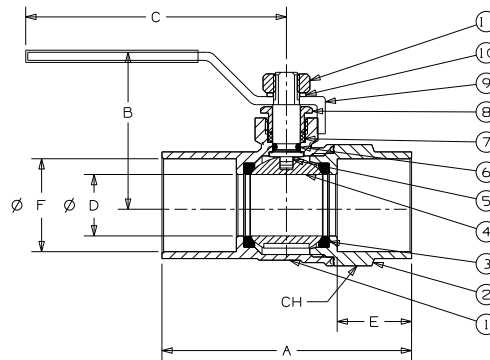

S-580-A
C x C

DIMENSIONS—WEIGHTS—QUANTITIES

Dimensions																
Size	T-580-A		S-580-A		B		C		D Port		T-580-A		S-580-A		Ctn. Qty	
	In.	mm.	In.	mm.	In.	mm.	In.	mm.	In.	mm.	Lbs.	Kg.	Lbs.	Kg.		
1/2	15	2.16	55	1.95	50	1.58	40	3.74	95	0.39	10	0.36	0.16	0.29	0.13	16
3/4	20	2.19	56	2.50	64	1.79	45	3.74	95	0.59	15	0.48	0.22	0.44	0.20	12
1	25	2.76	70	3.04	77	2.06	52	3.94	100	0.75	19	0.85	0.39	0.71	0.32	6
1¼	32	3.13	80	3.49	89	2.54	65	4.50	114	0.98	25	1.14	0.52	1.07	0.49	4
1½	40	3.40	86	3.98	101	2.59	66	5.00	127	1.18	30	1.71	0.78	1.48	0.67	2
2	50	3.73	95	4.76	121	2.95	75	6.18	157	1.46	37	2.41	1.09	2.41	1.09	2

S-580-A series to be soft soldered into lines using solder with the melting point not exceeding 470° F. Higher temperature solders will damage the seat material.