

200 PSI CWP Bronze Gate Valves

Bronze Body • Screw-in Bonnet • Non-Rising Stem • Solid Wedge • Compact Design • Full Port

200 PSI/14 Bar Non-Shock Cold Working Pressure



MATERIAL LIST

PART	SPECIFICATION
1. Handwheel Screw	Stainless Steel, Type 430
2. Handwheel	Aluminum
3. Stem	Bronze ASTM B 99 Alloy C65100 H04
4. Stem O-Ring	EPDM
5. Bonnet	Cast Brass ASTM B 584 Alloy C84400
6. Wedge	Cast Brass ASTM B 584 Alloy C84400
7. Body	Cast Brass ASTM B 584 Alloy C84400

* Ball Material of 1/4", 3/8" 1/2" and 3/4" Brass, ASTM B-16 Alloy 360, with hard chrome plate.



T-29
Threaded



S-29
Solder

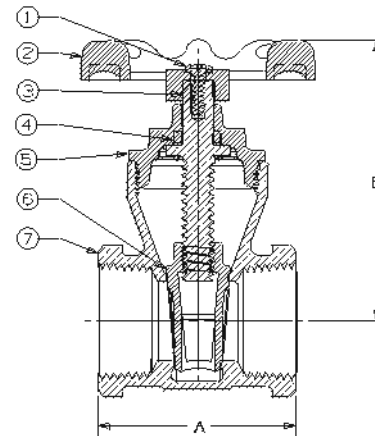

T-29
NPT x NPT

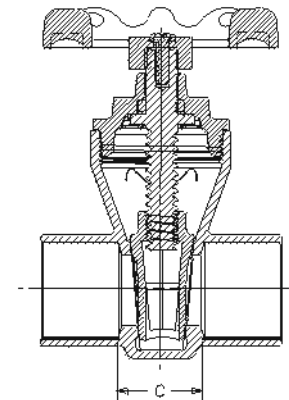

S-29
Cup x Cup

Size	Dimensions						Weight				
	A		B		C		T-29		S-29		
In. mm.	In.	mm.	In.	mm.	In.	mm.	Lbs.	Kg.	Lbs.	Kg.	
1/2	15	1.81	46	2.52	64	0.81	21	.48	.22	.42	.19
3/4	20	2.00	51	2.83	72	0.88	22	.75	.34	.65	.30
1	25	2.31	59	3.27	83	1.06	25	1.22	.55	1.11	.50
1 1/4	32	2.63	69	3.64	92	1.13	29	1.62	.74	1.38	.63
1 1/2	40	2.75	70	4.16	106	1.19	29	2.12	.96	1.98	.90
2	50	2.88	73	4.88	124	1.31	33	3.29	1.49	3.23	1.47