

## Kynar® (PVDF) Tru-Bloc Ball Valves True Union Red and Natural

150 psi at 73°F water—non-shock—full port

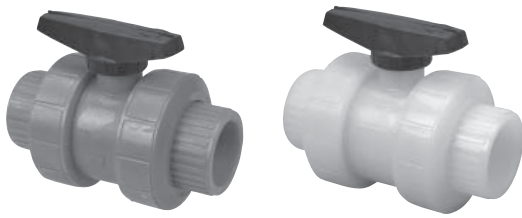

### Red Kynar

PVDF, absent of any color pigment, is opaque to ultraviolet light. So while PVDF is one of the few plastic materials that is not degraded by UV radiation, exposure of the fluid medium inside a piping system to direct sunlight can frequently adversely affect its stability. Therefore, all PVDF piping components, including valves that Chemtrol produces for general chemical service, contain an FDA-approved red pigment to mask the penetration of UV rays.

### Natural Kynar

PVDF Type I (polymerized in emulsion) homopolymer is notably free of metallic ions and foreign organic compounds. Extractable ions by 18-megohm water are in the low parts-per-billion. And since the resin does not require processing or other external additives to aid manufacturing or long-term stability, the hard-polish surface of components will remain intact, so that piping systems will not release particulate to the fluid medium. Further, there will be no surface micropores to encourage biological growth. Natural Kynar systems are intended for ultra high pure water and chemical services.

### Features

- The laying length of the body and the heavy-duty modified-acme threads in the union connections to the body have not changed in the 30-year history of the valve. This permits fouled valve replacement with a new body cartridge, which will fit the old union nuts. No change in piping length is required.
- Model-C design features, under the PTFE seats at both ends of the valve, ensure no leakage around the back-side of the seats. Open piping attached to a filled tank will not start to drip-leak following installation and test of a Chemtrol Tru-Bloc shut-off valve.
- Model-C design, with an energizer O-ring beneath the seat-carrier, enables the valve to automatically adjust for seat wear. Adjustments for envelope squeeze on seats and valve testing are done by machine during factory assembly. Upon installation, a hand-tightened union nut serves to compress the face-seal of a Chemtrol valve.
- Full port design produces minimum flow restriction with the lowest

possible pressure drop.

- Valves are manufactured and assembled without exposure to silicone compounds.
- Distinctive black handle indicates “open/close” and direction of flow at a distance. And molded-in arrows on top of the handle dictate rotational direction to personnel for easy operation within 90° stops. For applications requiring handle removal, the D-ring stem flats indicate “open/close” and a molded-in arrow on top of the stem indicates flow direction.
- Refer to the *Chemtrol Valve Actuation Guide* for a full selection of electrical and pneumatic actuators with accessories, including plastic housings and plastic mounting kits for field or factory assembly to valves.

### Notes

See page 2 for a list of *Components and Construction Materials*. For more insight into the selection of materials, refer to *Materials*, page 1. *Actuation Mounting Data* and a complete listing of *Optional Accessories* for ball valves begins on page 19. *Installation and Maintenance Instructions* for these valves appear on page 8. For specific relationships of pressure vs. temperature ratings, refer to *Engineering Data*, page 28. For *Chemtrol Valve Standards*, see page 29.

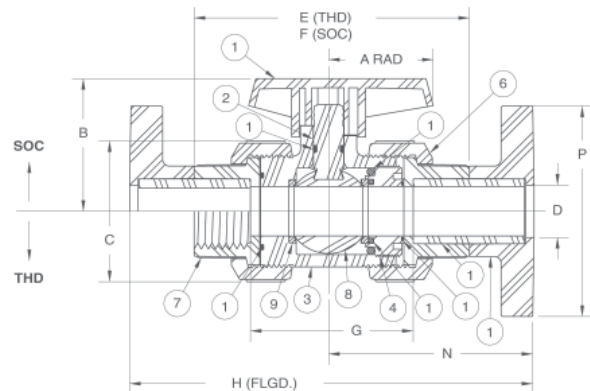

### Chemtrol Figure Numbers

Valve Sizes	Material	Elastomeric Trim	End Connections		
			Soc.	Thd.	Flgd.
1/2" – 4"	Red PVDF <sup>1</sup>	FKM	S65TB-V	T65TB-V	F65TB-V
1/2" – 4"	Natural PVDF <sup>1</sup>	FKM	S66TB-V	T66TB-V	F66TB-V

<sup>1</sup> No Kynar pipe, fittings, or valves are offered in the 1 1/4" size.

### Dimensions—Weights—Flow Coefficients

Valve Size <sup>4</sup>	Profile						End-to-End					Fluid Flow Coefficient C <sub>v</sub> <sup>3</sup>
	A <sup>1</sup>	B	C	D	N	P	E Thd.	F Soc.	G Soc.	H Flgd.	Approx. <sup>2</sup> Wt. Lbs.	
1/2	1.70	1.94	1.95	0.50	2.98	3.41	4.19	4.19	2.49	6.04	0.47	22
3/4	2.12	2.50	2.36	0.75	3.63	3.77	5.00	5.00	3.05	7.32	0.84	55
1	2.12	2.69	2.75	1.00	4.13	4.15	5.50	5.50	3.30	8.06	1.15	112
1 1/2	2.56	3.74	3.98	1.50	4.98	4.86	6.76	6.76	4.06	9.92	2.59	285
2	2.92	4.25	5.13	2.00	5.78	5.82	8.01	8.01	5.06	11.41	5.30	540
3	4.00	5.59	6.99	2.90	7.42	7.31	10.39	10.39	6.70	14.87	12.58	1348
4	8.00	6.05	8.54	3.95	8.52	8.70	12.22	12.22	7.78	17.52	24.41	2602

<sup>1</sup> Handle is not symmetrical about the centerline. Dimension shown represents the longest operational radius, but the handle position must be rotated 180° from that shown for the 4" size.

<sup>2</sup> Weight shown represents the socket figure.

<sup>3</sup> C<sub>v</sub> values were computed for the basic valve laying lengths (G).

<sup>4</sup> No pipe, fittings, or valves are offered in the 1 1/4" size.