

## PVC and CPVC Tru-Bloc Ball Valves True Union

### 150 psi at 73°F water—non-shock—full port

As a result of continuous testing and improvements since the inception of the True Union Ball Valve, two distinct model changes have occurred. The original True Union design had a seat-carrier that slid into the smooth bore of the valve body, but it was not directly retained within the body. Thus, by adjusting the tightness of the union nut, the squeeze of the seats against the ball would be maintained.

The first major evolution to the True Union Ball Valve, Model-B, introduced the Tru-Bloc concept, a functional safety feature. With this design the seat-carrier was indirectly held within the valve body by means of a retainer ring, which was attached to the inside of the body by threads. Should the union nut and end connector on the “adjust” side of the valve be removed, this change negates the possibility that pressure on the other side could blow the internal components and fluid medium out of the open valve end to injure the service mechanic and/or surrounding equipment.

The current design evolution, Model-C, retains the traditional True Union feature and the Tru-Bloc concept. Now, a one-piece seat-carrier is screwed directly into the valve body, eliminating the need of a retainer ring. The provision for external seat adjustment is no longer required because an O-ring, located in a groove beneath the seat, has been added to the new seat-carrier. The shape of the O-ring groove prevents damage to the rubber from excessive compression during assembly of the valve. Yet automatic adjustment for seat wear can result from decompression of the seat-energizer.

### Features

- The laying length of the body and the heavy-duty modified-acme threads in the union connections to the body have not changed in the three distinct models’ 30-year history of the valve. This permits fouled valve replacement with a new body cartridge, which will fit the old union nuts. No change in piping length is required.

### Chemtrol Figure Number

Valve Style	Elasto-meric Trim	PVC			CPVC		
		Soc.	Thd.†	Flgd.	Soc.	Thd.†	Flgd.
TUFGM	U45TB-V* EPDM	U45TB-V* U45TB-E*	F45TB-V U45TB-E*	U51TB-V* F45TB-E	U51TB-V* U51TB-E*	F51TB-V F51TB-E	F51TB-V F51TB-V

\* As original equipment, 1/2" - 2" True Union Tru-Bloc valve models are supplied with universal connectors (i.e., a set of both socket and thread end connectors). For 3" - 6" sizes, replace U in the Fig. No. with "S" or "T" for Soc. or Thd. models respectively.

† Thread end connections are not available for 6" valves.

- Model-C design features ensure no leakage around the back-side of the seats. Open piping attached to a filled tank will not start to drip-leak following installation and test of a Chemtrol Tru-Bloc shut-off valve.
- Model-C design, with an energizer O-ring beneath the seat-carrier, enables the valve to automatically adjust for seat wear. Adjustments for envelope squeeze on seats and valve testing are done by machine during factory assembly. Upon installation, a hand-tightened union nut serves to compress the face-seal of a Chemtrol valve.
- Full port design produces minimum flow restriction with the lowest possible pressure-drop.
- Valves are manufactured and assembled without exposure to silicone compounds.
- Distinctive orange handle indicates “open/close” and direction of flow at a distance. And molded-in arrows on top of the handle dictate rotational direction to personnel for easy operation within 90° stops. For applications requiring handle removal, the D-ring stem flats indicate “open/close” and a molded-in arrow on top of the stem indicates flow direction.
- Refer to the *Chemtrol Valve Actuation Guide* for full selection of electrical and pneumatic actuators with accessories, including plastic housings and plastic mounting kits for field or factory assembly to valves.

### Notes

See page 2 for a list of *Components and Construction Materials*. For more insight in the selection of materials, refer to *Materials*, page 1. *Actuation Mounting Data* and a complete listing of *Optional Accessories* for ball valves begins on page 19. *Installation and Maintenance Instructions* for these valves appear on page 8. For specific relationships of pressure vs. temperature ratings, refer to *Engineering Data*, page 28. For *Chemtrol Valve Standards*, see page 29.

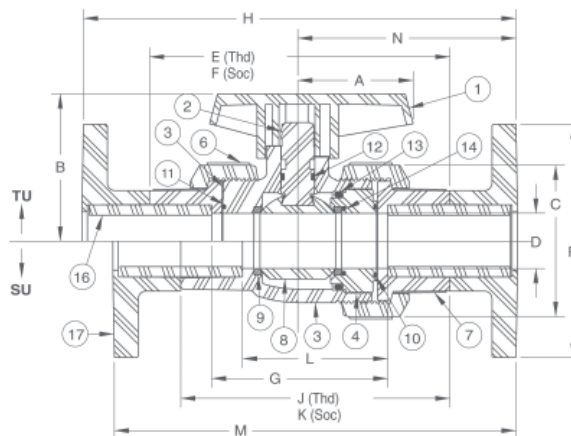

### Dimensions—Weights—Flow Coefficients

Valve Size	TU Figures Profile						TU Figures End-to-End (1/2" thru 6")					Fluid Flow Coefficient C <sub>v</sub> <sup>3</sup> TU
	A1	B	C	D	N	P	E Thd.	F Soc.	G Soc.	H Flgd.	Approx. <sup>2</sup> Wt. Lbs.	
1/2	1.70	1.94	2.00	.50	2.98	3.50	4.00	4.19	2.41	6.19	0.48	22
3/4	2.12	2.50	2.44	.75	3.63	3.88	4.63	5.00	2.97	7.25	0.86	55
1	2.12	2.69	2.86	1.00	4.13	4.26	5.18	5.50	3.22	8.06	1.23	112
1 1/4	2.56	3.74	4.08	1.25	4.70	4.62	6.10	6.47	3.94	9.50	2.64	178
1 1/2	2.56	3.74	4.08	1.50	4.98	5.00	6.15	6.76	3.98	10.00	2.80	285
2	2.92	4.25	5.25	2.00	5.78	6.00	7.35	8.01	4.98	11.38	5.37	540
3	4.00	5.59	7.18	3.00	7.42	7.50	10.39	10.39	6.58	14.63	11.25	1348
4	8.00	6.05	8.78	4.00	8.52	9.00	12.22	12.22	7.66	17.63	17.68	2602
6	8.00	6.05	8.78	4.00	11.90	11.05	NA	30.22	24.16	24.08	29.25	2602

1 Handle is not symmetrical about centerline. Dimensions shown represent the longest operational radius. The handle position is correctly shown for the 1/2" - 3" True Union valve style, but the position must be rotated 180° from that shown for the 4" - 6" True Unions.

2 Weight for 1/2" - 2" TU figures includes both sets of end connectors or soc. end connections only for 3" - 6" sizes. The material represented is PVC in all cases.

3 C<sub>v</sub> values computed for basic valve laying lengths (G & L).

4 The 6" valve is fabricated by solvent cementing either flange of socket couplings onto the ends of a 4" TU valve with plain-end concentric reducer pipe nipples. Threaded figure not available.