

Class 150 Bronze Check Valves

Bolted Bonnet • Horizontal Swing • Regrinding Type •
Renewable Seat and Disc

150 PSI/10.3 Bar Saturated Steam to 366° F/185° C
300 PSI/20.7 Bar Non-Shock Cold Working Pressure

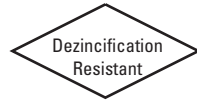

CONFORMS TO MSS SP-80

MATERIAL LIST

PART	SPECIFICATION
1. Bonnet	Bronze ASTM B 62
2. Body	Bronze ASTM B 62
3. Hinge Pin	ASTM B 371 Alloy C69400
4. Disc Hanger	Bronze ASTM B 62
5. Hanger Nut	ASTM B 62 Alloy C83600
6. Disc	Bronze ASTM B 62 (B)
7. Hinge Pin Plug	Bronze ASTM B 140 Alloy C31400
8. Seat Ring	Bronze ASTM B 62 C83600
9. Body Bolt	Zinc Plated Steel
10. Body Nut	Zinc Plated Steel
11. Gasket	Aramid Fibers with Graphite



S-433-B
Solder

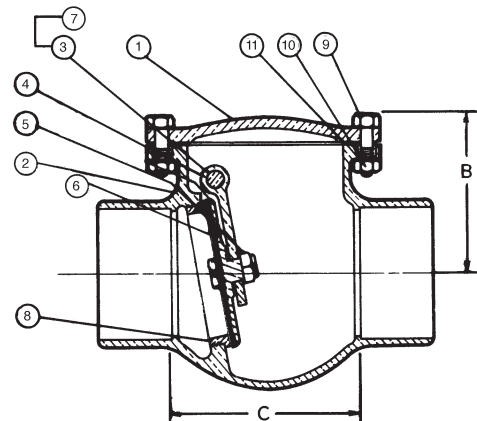

S-433-B
C x C

DIMENSIONS—WEIGHTS—QUANTITIES

Size	Dimensions				Weight		Master Ctn. Qty.	
	B		C		Lbs.	Kg.		
In. mm.	In.	mm.	In.	mm.				
4	100	6.19	157	7.38	187	37	16.78	1

NIBCO check valves may be installed in both horizontal and vertical lines with upward flow or in any intermediate position. They will operate satisfactorily in a declining plane (no more than 15°).

Warning – Do Not Use For Reciprocating Air Compressor Service.

◆ For detailed Operating Pressure, refer to Pressure Temperature Chart on page 111.