

150 PSI Butterfly Valves

Ductile Iron Body • Cartridge Liner • Double Flanged

Sizes 30", 36", 42" and 48"

Install between Std. ANSI Class 125/150 Flanges
100 PSI bi-directional dead end service rating without a downstream flange required

CONFORMS TO MSS-SP67

MATERIAL LIST

| PART | SPECIFICATION |
|--------------------|--|
| 1. Body | Ductile Iron ASTM A 536 |
| 2. Bushing | Bronze ASTM B 584 Grade C83600 |
| 3. Lower Stem | Stainless Steel ASTM A 582 Type 416 Stainless Steel ASTM A 276 Type 316SS |
| 3a. Upper Stem | Stainless Steel ASTM A 582 Type 416 Stainless Steel ASTM A 276 Type 316SS |
| 4. Seat Back Ring | Phenolic Resin, Aluminum B26 30" - 36" eight set screws in backing 42" - 48" ten set screws in backing |
| 5. Seat | Rubber - BUNA (NBR) Rubber - EPDM |
| 6. Disc | Aluminum Bronze ASTM B 148 C95400 Ductile Iron ASTM A 536 65-45-12 (Nickel Plated) Stainless Steel ASTM A 351 Grade CF8M |
| 7. Taper Pin(3) | Stainless Steel ASTM A 582 Type 416 or 17-4PH |
| 8. Rivet | Steel |
| 9. Nameplate | Aluminum |
| 10. Bushing | Bronze ASTM B 584 C83600 |
| 11. Flat Key | Steel ASTM A 108 1045 |
| 12. Bushing | Bronze ASTM B 584 C83600 |
| 13. Socket Bolt | Steel ASTM A 307 |
| 14. O-Ring | Rubber BUNA (NBR) |
| 15. Bottom Plate | Steel ASTM A-108 1035 |
| 16. Thrust Bearing | Bearing Steel |
| 17. Washer | Steel |

DIMENSIONS — WEIGHTS

| Size | | | | | | | | | | | | |
|------|------|-------|-------|-------|------|-------|---------|-------|-------|---------|--|--|
| In. | mm. | D1 | D2 | D4 | D5 | D7 | D8 Dia. | D9 | D10 | D11 | | |
| 30 | 750 | 29.30 | 36.00 | 10.00 | 0.71 | 38.74 | 2.50 | 11.81 | 28.56 | 1¼-7UNC | | |
| 36 | 900 | 34.04 | 42.75 | 10.00 | 0.71 | 46.00 | 2.95 | 11.81 | 33.09 | 1½-6UNC | | |
| 42 | 1050 | 40.55 | 49.50 | 10.00 | 0.71 | 53.00 | 3.74 | 11.81 | 39.33 | 1½-6UNC | | |
| 48 | 1200 | 45.67 | 56.00 | 11.75 | 0.87 | 59.50 | 4.13 | 13.78 | 44.35 | 1½-6UNC | | |

| Size | | | | | | | | | | | Lug Weight | |
|------|------|-------|-------|-------|-------|------|----|----|------|-------------|------------|------|
| In. | mm. | C | L | A | B | E | N1 | N2 | T | Key Size | Lbs. | Kg. |
| 30 | 750 | 6.57 | 6.81 | 50.63 | 26.00 | 2.60 | 8 | 28 | 2.12 | .71 x 2.50 | 926 | 420 |
| 36 | 900 | 8.00 | 8.31 | 58.82 | 28.35 | 4.65 | 8 | 32 | 2.38 | .79 x 3.94 | 1482 | 660 |
| 42 | 1050 | 9.88 | 10.28 | 70.28 | 33.78 | 5.91 | 8 | 36 | 2.62 | .98 x 5.51 | 1971 | 896 |
| 48 | 1200 | 10.88 | 11.26 | 76.96 | 37.04 | 5.91 | 8 | 44 | 2.75 | 1.10 x 5.51 | 2816 | 1280 |

LD 1000/LD 1100

Lug Style
EPDM or Buna-N Liner
Aluminum Bronze Disc

LD 1010

Lug Style
EPDM Liner
Ductile Iron Disc

LD 1022

Lug Style
EPDM Liner
Stainless Steel Disc

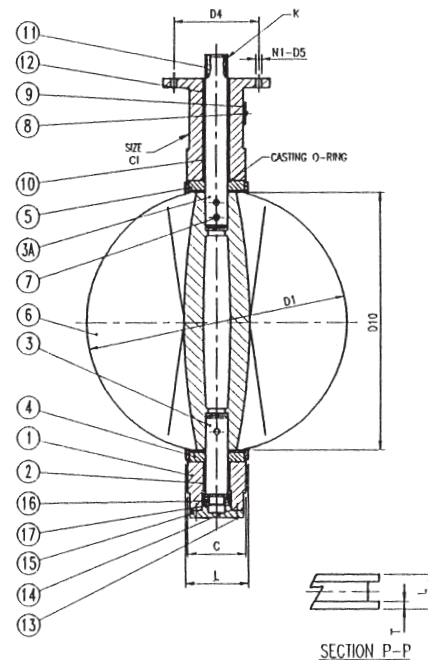
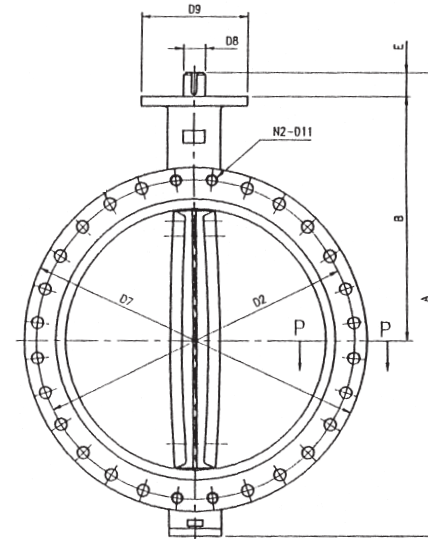

NOT RECOMMENDED
FOR STEAM SERVICE