

Class 125 Iron Body Gate Valves

Bolted Bonnet • Non-Rising Stem • Solid Wedge • Bronze Mounted

125 PSI/8.6 Bar Saturated Steam to 353° F/178° C
200 PSI/13.8 Bar Non-Shock Cold Working Pressure
to -20° F to 150° F/-29° C to 66° C◆

CONFORMS TO MSS SP-70

MATERIAL LIST

PART	SPECIFICATION
1. Handwheel Nut	Steel ASTM A 307
2. Identification Plate	Aluminum
3. Handwheel or Square Operating Nut	Cast Iron ASTM A 126 Class B
4. Stem	Brass ASTM B 16 Alloy C36000
5. Gland Follower Nut	Bronze ASTM F 467 Alloy C27000
6. Gland Follower	Cast Iron ASTM A 126 Class B or Ductile Iron ASTM A 536
7. Gland Follower Bolt	Steel ASTM A 307
8. Packing Gland	Zinc Plated Powdered Iron ASTM B 783 or Brass ASTM B 16
9. Stuffing Box	Cast Iron ASTM A 126 Class B
10. Packing	Synthetic Fibers with Graphite
11. Stuffing Box Gasket	Synthetic Fibers
12. Bonnet	Cast Iron ASTM A 126 Class B
13. Body Bolt	ASTM A 307
14. Body Gasket	Synthetic Fibers
15. Body Nut	Steel ASTM A 307
16. ¹ Wedge Bushing	Cast Bronze ASTM B 584 Alloy C84400
17. Seat Ring	Cast Bronze ASTM B 584 Alloy C84400
18. Wedge Face Ring	Cast Bronze ASTM B 584 Alloy C84400
19. ¹ Wedge	Cast Iron ASTM A 126 Class B
20. Body	Cast Iron ASTM A 126 Class B
21. Stuffing Box Nut	Steel ASTM A 307 (not shown)

¹ Sizes thru 6" have Bronze Wedges. Sizes 8" thru 12" made with Cast Iron Wedge with Bronze Bushing and Wedge Face Rings.

DIMENSIONS—WEIGHTS—QUANTITIES

Size	Dimensions														F-619		T-619	
	F-619		T-619		B	C	D	E	F-619	T-619	Lbs.	Kg.	Lbs.	Kg.				
	A	A	A	A														
2	50	7.00	178	5.63	143	11.00	279	7	178	6.00	152	.63	16	35	16	25	11	
2½	65	7.50	191	5.88	149	12.50	318	7	178	7.00	178	.69	17	49	22	33	15	
3	80	8.00	203	6.13	156	13.50	343	8	203	7.50	191	.75	19	60	27	42	19	
4	100	9.00	229	6.50	165	15.75	400	10	254	9.00	229	.94	24	90	41	61	28	
5	125	10.00	254	x	x	17.00	432	10	254	10.00	254	.94	24	129	59	x	x	
6	150	10.50	267	x	x	21.00	533	12	305	11.00	279	1.00	25	161	73	x	x	
8	200	11.50	292	x	x	25.00	635	14	356	13.50	343	1.13	29	277	126	x	x	
10	250	13.00	330	x	x	29.00	737	16	406	16.00	406	1.19	30	415	188	x	x	
12	300	14.00	356	x	x	34.50	876	18	457	19.00	483	1.25	32	631	287	x	x	
14	350	15.00	381	x	x	40.38	1026	24	610	21.00	533	1.38	35	869	394	x	x	
16	400	16.00	407	x	x	45.75	1162	24	610	23.50	597	1.44	37	1224	555	x	x	

x Not available this size.



F-619
Flanged



T-619
Threaded



F-619-SO
Flanged
With Square Op. Nut

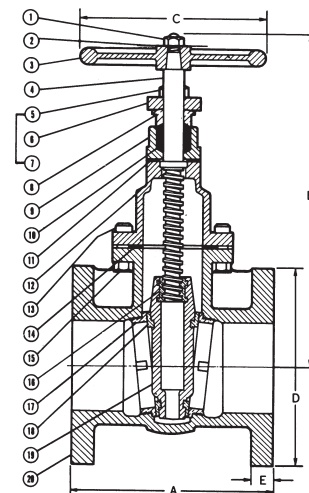

F-619
Flg x Flg

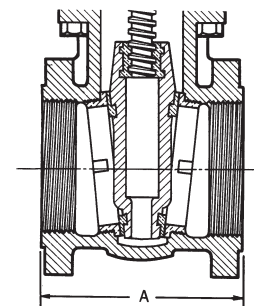

T-619
NPT x NPT

FREEZING WEATHER PRECAUTION: Subsequent to testing a piping system, valves should be left in an open position to allow complete drainage.

Position indicators available, see page 95.

◆For detailed Operating Pressure, refer to Pressure Temperature Chart on page 111.