

# 250 PSI CWP Iron Body Gate Valve

Bolted Bonnet • Non-Rising Stem • Resilient Wedge • Flanged by MJ Ends

**250 PSI/17.2 Bar Non-Shock Cold Working Pressure**

Conforms to AWWA C 509 & C 515

## MATERIAL LIST

PART	SPECIFICATION
1. Valve Body	Ductile Iron ASTM A 536
2. Resilient Wedge	Ductile Iron ASTM A 536/EPDM ASTM D 2000
3. Wedge Nut	Bronze ASTM B 584 UNS C83600
4. Stem	Bronze ASTM B 150 UNS C61400
5. Bonnet Gasket	EPDM ASTM D 2000
6. Bonnet Screw	Alloy Steel ASTM A 574M Zinc Plated
7. Bonnet	Ductile Iron ASTM A 536
8. Stem Primary O-Ring	EPDM ASTM D 2000
9. Stem Thrust Washer (lower)	Bronze ASTM B 584 UNS C83600
10. Stem Thrust Washer (upper)	Stainless Steel ASTM A 276 UNS S41000
11. Gland Seal O-Ring	EPDM ASTM D 2000
12. Stem Seal Bushing	Bronze ASTM B 584 UNS C83600
13. Stem Secondary O-Ring (2)	EPDM ASTM D 2000
14. Gland Flange	Ductile Iron ASTM A 536
15. Gland Flange Screw	Alloy Steel ASTM A 574M Zinc Plated
16. Stem Ring Wiper	EPDM ASTM D 2000
17. Square Operating Nut	Cast Iron ASTM A 126 B
17A. Handwheel (optional)	Ductile Iron ASTM A 536
18. Flat Washer	Carbon Steel Zinc Plated
19. Screw	Alloy Steel ASTM A 574M Zinc Plated



FM-619-RW



FM-619-RW-SON

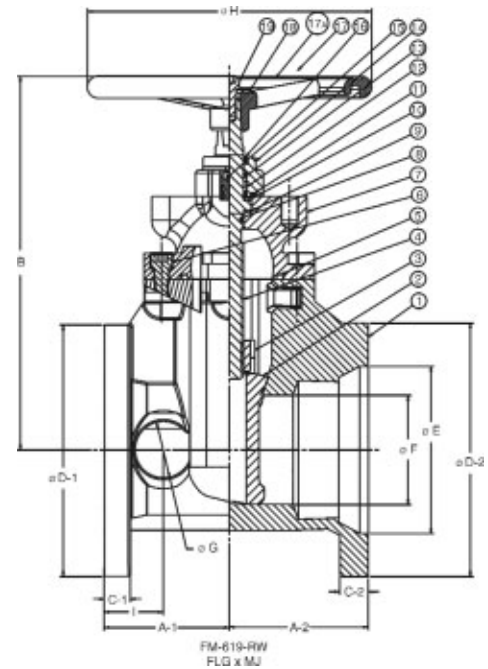

Coating — Electrostatically applied fusion-bonded epoxy 10-14 mil. inside and outside. FM619RWIR.pdf

Meets or exceeds AWWA C 550

Coating is NSF and FDA certified

Maximum operating temperature 160°F/71°C.

## DIMENSIONS—WEIGHTS—QUANTITIES

Size	Dimensions																
	A-1		A-2		B		C-1		C-2		D-1		D-2		E		F
In. mm.	In. mm.	In. mm.	In. mm.	In. mm.	In. mm.	In. mm.	In. mm.	In. mm.	In. mm.	In. mm.	In. mm.	In. mm.	In. mm.	In. mm.	In. mm.	In. mm.	In. mm.
3 80	4.0 101.5	4.0 101.5	12.6 321	0.75 19.0	0.94 24	7.5 191	7.7 195.3	4.9 126	3.1 80								
4 100	4.5 114.5	5.0 127.0	13.5 344	0.94 24.0	1.00 26	9.0 229	9.1 232.0	6.0 153	3.9 100								
6 150	5.3 133.5	5.7 146.0	17.4 441	1.00 25.4	1.06 27	11.0 279	11.1 282.5	8.1 206	5.9 150								
8 200	5.7 146.0	5.7 146.0	20.8 529	1.13 28.6	1.12 28	13.5 343	13.4 339.6	10.3 261	7.9 200								
10 250	6.5 165.0	6.5 165.0	24.2 614	1.19 30.2	1.18 30	16.0 406	15.6 396.8	12.3 313	9.8 250								
12 300	7.0 178.0	7.0 178.9	27.6 700	1.25 31.8	1.25 32	19.0 483	17.9 454.2	14.4 367	11.8 300								

Size	Dimensions										Turns to Open	Weight		
	G		H		I		Flanged B.C.		MJ B.C.			No. holes Flanged	No. holes M-Joint	Lbs.
In. mm.	In. mm.	In. mm.	In. mm.	In. mm.	In. mm.	In. mm.	In. mm.	In. mm.	In. mm.	In. mm.	In. mm.			
3 80	2.1 54	10.2 260	1.73 44	6.00 152	6.19 157	4	4	10.8	43	20				
4 100	2.1 54	10.2 260	2.13 54	7.50 191	7.50 191	8	4	13.0	70	36				
6 150	2.5 64	14.8 375	2.24 57	9.50 241	9.50 241	8	6	15.7	112	51				
8 200	2.8 70	14.8 375	2.48 63	11.75 298	11.75 298	8	6	17.3	170	77				
10 250	2.8 70	15.7 400	2.56 65	14.25 362	14.00 356	12	8	21.4	267	121				
12 300	3.4 86	19.7 500	2.91 74	17.01 432	16.25 413	12	8	25.3	388	176				

### END CONNECTIONS

A-1	Center to face on Flanged end
A-2	Center to face on MJ end
B	Center to top of stem
C-1	Flange thickness on Flanged end
C-2	Flange thickness on MJ end
D-1	Flange O.D. on Flanged end
D-2	Flange O.D. on MJ end
E	O-ring groove diameter or MJ end
F	Waterway diameter
G	Boss diameter on Flanged end
H	Handwheel diameter
I	Face to center of boss on Flanged end

**FREEZING WEATHER PRECAUTIONS:** Subsequent to testing a piping system, valves should be left in an open position to allow complete drainage.