

250 PSI CWP Iron Body Gate Valves

Bolted Bonnet • Non-Rising Stem • Resilient Wedge • Flanged Ends

250 PSI/17.2 Bar Non-Shock Cold Working Pressure

CONFORMS TO AWWA C509

MATERIAL LIST

PART	SPECIFICATION
1. Valve Body	Ductile Iron ASTM A 536
2. Resilient Wedge	Ductile Iron ASTM A 536/EPDM ASTM D 2000
3. Wedge Nut	Bronze ASTM B 584 UNS C83600
4. Stem	Bronze ASTM B 150 UNS C61400
5. Bonnet Gasket	EPDM ASTM D 2000
6. Bonnet Screw	Alloy Steel ASTM A 574M Zinc Plated
7. Bonnet	Ductile Iron ASTM A 536
8. Stem Primary O-Ring	EPDM ASTM D 2000
9. Stem Thrust Washer (lower)	Bronze ASTM B 584 UNS C83600
10. Stem Thrust Washer (upper)	Stainless Steel ASTM A 276 UNS S41000
11. Gland Seal O-Ring	EPDM ASTM D 2000
12. Stem Seal Bushing	Bronze ASTM B 584 UNS C83600
13. Stem Secondary O-Ring (2)	EPDM ASTM D 2000
14. Gland Flange	Ductile Iron ASTM A 536
15. Gland Flange Screw	Alloy Steel ASTM A 574M Zinc Plated
16. Stem Ring Wiper	EPDM ASTM D 2000
17. Square Operating Nut	Cast Iron ASTM A 126-B
17A. Handwheel (Optional)	Ductile Iron ASTM A 536
18. Flat Washer	Carbon Steel Zinc Plated
19. Screw	Alloy Steel ASTM A 574M Zinc Plated

Coating – Electrostatically applied fusion-bonded epoxy 10-14 mil. inside and outside. Meets or exceeds AWWA C550. Coating is NSF and FDA certified.

Maximum operating temperature 160° F/71° C.



F-619-RW

Flanged

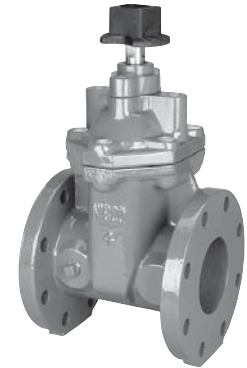

F-619-RW-SON

Flanged

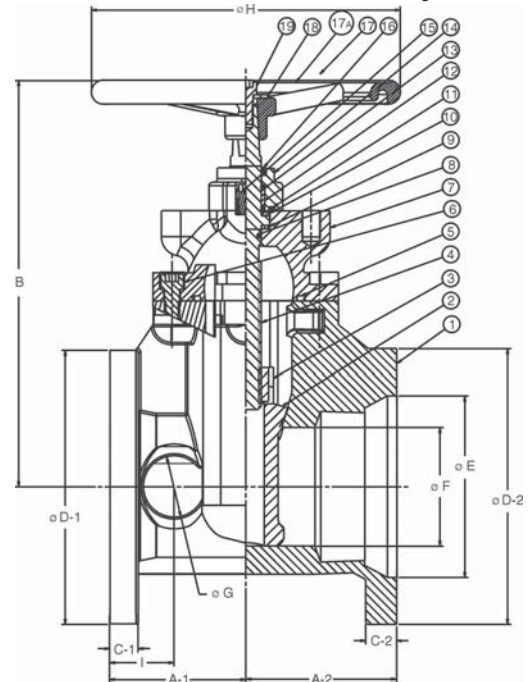

FM-619-RW
FLG x MJ
F-619-RW
Flg x Flg
Shown with optional handwheel

DIMENSIONS—WEIGHTS—QUANTITIES

Size	Dimensions														Bolt Circle	Flange Holes	Turns to Open	Weight			
	A		B		C		D		F		G		H					Lbs.	Kg.		
In. mm.	In.	mm.	In.	mm.	In.	mm.	In.	mm.	In.	mm.	In.	mm.	In.	mm.	In.	mm.					
2	50	7.0	178	10.0	255	0.63	16.0	6.0	152	1.42	36	1.6	40	7.9	200	4.75	121	4	6.5	30	14
2½	65	7.5	190	11.3	287	0.69	17.5	7.0	178	1.50	38	1.6	40	7.9	200	5.50	140	4	8.8	35	16
3	80	8.0	203	12.6	321	0.75	19.0	7.5	191	1.73	44	2.1	54	10.2	260	6.00	152	4	10.6	45	20
4	100	9.0	229	13.5	344	0.94	24.0	9.0	229	2.13	54	2.1	54	10.2	260	7.50	191	8	13.0	71	32
6	150	10.5	267	17.4	441	1.00	25.4	11.0	279	2.24	57	2.5	64	14.8	375	9.50	241	8	15.6	122	55
8	200	11.5	292	20.8	529	1.13	28.6	13.5	343	2.48	63	2.8	70	14.8	375	11.75	298	8	17.3	196	89
10	250	13.0	330	24.2	614	1.19	30.2	16.0	406	2.56	65	2.8	70	15.7	400	14.25	362	12	21.4	294	134
12	300	14.0	356	27.6	700	1.25	31.8	19.0	483	2.91	74	3.4	86	19.7	500	17.00	432	12	25.3	426	194
14	350	15.0	381	31.8	807	1.38	35.0	21.0	533	2.95	75	3.1	80	19.7	500	18.75	476	12	44	600	273
16	400	16.0	406	34.1	869	1.46	37.0	23.5	597	3.00	77	3.1	80	19.7	500	21.25	540	16	50	810	369

FREEZING WEATHER PRECAUTION: Subsequent to testing a piping system, valves should be left in an open position to allow complete drainage.